



Poly Studio P5 User Guide

SUMMARY

This guide provides end-users with task-based user information for the featured product.



Legal information

Copyright and license

© Copyright February 2025, HP Development Company, L.P. The information contained herein is subject to change without notice. The only warranties for HP products and services are set forth in the express warranty statements accompanying such products and services. Nothing herein should be construed as constituting an additional warranty. HP shall not be liable for technical or editorial errors or omissions contained herein.

Trademark credits

All third-party trademarks are the property of their respective owners.

Privacy policy

Poly complies with applicable data privacy and protection laws and regulations. Poly products and services process customer data in a manner consistent with the Poly Privacy Policy. Please direct comments or questions to privacy@poly.com.

Open source software used in this product

This product contains open source software. You may receive the open source software from Poly up to three (3) years after the distribution date of the applicable product or software at a charge not greater than the cost to Poly of shipping or distributing the software to you. To receive software information, as well as the open source software code used in this product, contact Poly by email at open.source@poly.com.

Table of contents

About this guide	1
Audience, purpose, and required skills	1
Icons used in Poly documentation	1
Getting Started	2
Poly Studio P5 Hardware Overview	2
Use the Poly Studio P5 Device Privacy Shutter	3
Computer and Cable Requirements	3
P5 LED Status Indicators	4
Basic tips for great video conferences	4
Advanced tips for great video conferences	5
Accessibility Features	7
Users Who Are Deaf or Hard of Hearing	7
Users with Limited Mobility	7
Using Your Poly Studio P Series Device	8
Default Poly Studio P Series Device Features	8
Download and Install the Poly Lens Desktop App	8
Set Poly P Series Device as the Default Audio and Video Device.....	8
Restart Your Device	9
Updating Firmware.....	9
Getting help	10
HP Inc. addresses.....	10
Document information	10

About this guide

This guide describes how to use the Poly Studio P5 personal video bar.





Audience, purpose, and required skills

This guide is intended for beginning users, as well as intermediate and advanced users, who want to learn more about the features available with their Poly Studio P5 device.

You can use the features in this guide without having Lens Desktop installed on your connected computer.

Icons used in Poly documentation

This section describes the icons used in Poly Documentation and what they mean.

-
-  **WARNING!** Indicates a hazardous situation that, if not avoided, **could** result in serious injury or death.
 -  **CAUTION:** Indicates a hazardous situation that, if not avoided, **could** result in minor or moderate injury.
 -  **IMPORTANT:** Indicates information considered important but not hazard-related (for example, messages related to property damage). Warns the user that failure to follow a procedure exactly as described could result in loss of data or in damage to hardware or software. Also contains essential information to explain a concept or to complete a task.
 -  **NOTE:** Contains additional information to emphasize or supplement important points of the main text.
 -  **TIP:** Provides helpful hints for completing a task.
-

Getting Started

Before you use your device, familiarize yourself with its features.

Poly Studio P5 Hardware Overview

The following figures display the hardware features on the Poly Studio P5 webcam. The table lists each feature numbered in the figures.

Front view

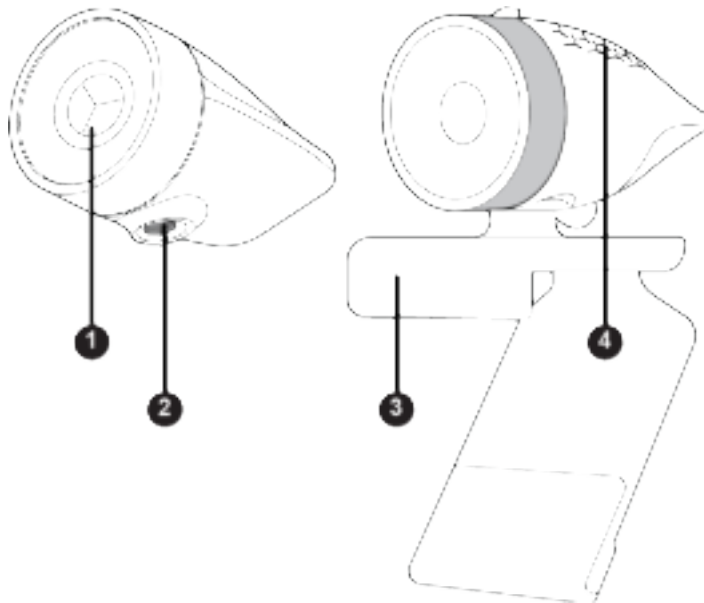

Table 2-1 Poly Studio P5 feature descriptions

Ref. number	Feature	Feature Description
1	Camera	Camera with a privacy shutter that you can manually open or close
2	Clamp attachment point	Attachment point for camera clamp
3	Monitor clamp	Adjustable monitor clamp
4	Microphone	Directional microphone that captures audio

System port

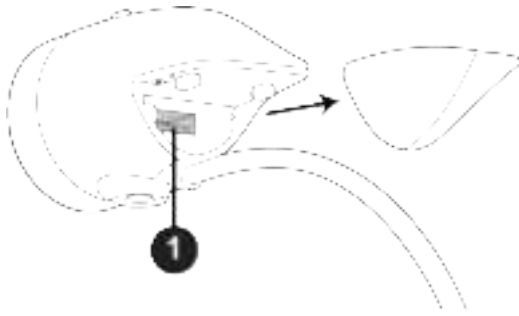

Table 2-2 Poly Studio P5 port description

Ref. number	Port description
1	USB-A port

Use the Poly Studio P5 Device Privacy Shutter

Your Poly Studio P5 device provides a built-in physical cover that blocks the camera lens to protect your privacy.

- Do one of the following:
 - To open the shutter, rotate the privacy shutter ring counterclockwise until it clicks. The LED illuminates when fully open.
 - Rotate the privacy shutter ring clockwise to close the shutter.

Figure 2-1 Poly Studio P5

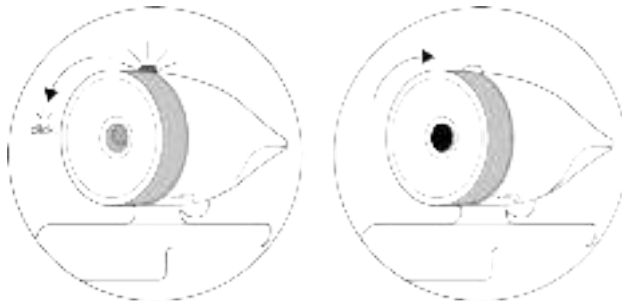

Computer and Cable Requirements

Make sure that your computer and USB cable meet the following requirements to use a Poly Studio P Series device as the camera and audio accessory.

Your computer must have one of the following operating systems:

- Windows 10 and 11
- macOS versions 12.6 and 13.5

- Chrome OS - Resolutions of 3840 x 2160 and 2560 x 1440 may not be supported on all Chromebook models

The Poly Studio P Series devices only support the USB cable that came with your system.

- Using a third-party USB-C to USB-C cable may affect device performance, or your device may not work at all.
- Using a third-party USB-C to USB-A adapter may affect video quality.
- Connecting your device to a USB 2.1 or 2.0 port or using a USB 2.0 cable may prevent you from receiving full 4K video from your Poly Studio P5 device.

P5 LED Status Indicators

Your device provides an LED above the camera to help you understand the device's behaviors. The following table lists each LED and its associated status.

Table 2-3 Basic Poly Studio P5 LED Indicators Status

Indicator	Status
Solid white	Device is powered on, the shutter is open, and the device is idle
Solid green	Camera is active (in use or displaying local video preview out of a call)
Blinking yellow	Firmware update in progress
Off	Shutter is closed and no video is streaming

Basic tips for great video conferences

Use the following basic tips and guidelines to enhance or improve your experiences during video conferences.

- Mount and position the camera so that your eyes are level with the top third of your screen and your face appears in the middle area of the video stream.



- Avoid wearing bright colors, all-light or all-dark clothing, or very busy patterns like small checks or narrow stripes. Light pastels and muted colors look the best on the screen.
- Preview your video stream before you join a meeting to make sure that you don't have shadows on your face and that your camera settings are configured correctly.
- Speak in your normal voice.

Advanced tips for great video conferences

Use the following basic tips and guidelines to enhance or improve your experiences during video conferences.

Camera and People Positioning

- Try not to fidget too much, especially if you're the only one on camera.
- Include all the people in the room (if possible), or introduce everyone in the room at the beginning of a meeting.



- Keep the view focused on people and not the background or room furnishings.
- In an office, position the monitor to an appropriate angle to avoid capturing potential distractions in your video (for example, other people, pets, or TVs).

Clothing, Furnishings, and Backgrounds

- To avoid disruptions, exclude the following from the camera view: light sources, tables, chairs, walls, busy decorations, and the floor.
- To avoid funny effects, wear clothes that contrast with the background instead of blending into it and make sure nothing in the background seems to stick out of anyone's head.
- Avoid glossy tabletops, strong colors, or bold wood grain in the room. The best table surface color is a flat satin finish in neutral gray.
- A wall that's painted light gray with a touch of blue works best as a background. Video conferencing systems use a gray or blue reference image to process the video, so a background in that color helps to enhance the video you send.
- Try to keep dry-erase whiteboards out of the camera field of view. Be aware that other people in the meeting might see what's written on the whiteboards.

Lighting

- Close any curtains, drapes, or blinds over your windows. Daylight is a variable light source and can conflict with interior room lighting.
- Bright lighting increases the range of in-focus objects, but inappropriate direct lighting might make you look harsh or somber. Poly recommends using indirect fluorescent lighting in a midrange, neutral color temperature (3600 K to 4500 K). You can find the color temperature of your lighting on the packaging.

Audio and Noise

- Mute your audio when you're silent or before you move your audio device.

- Keep your windows and doors closed to minimize unwanted noises.
- Close any drapes or blinds over your windows. The glass from windowpanes can cause issues with acoustics due to reflection.
- On the Poly Studio P5, Poly NoiseBlockAI helps the microphone eliminate unwanted noises while picking up your voice. If you're not using Poly NoiseBlockAI technology, consider these additional audio suggestions:
 - Don't obstruct your microphone with papers or other objects.
 - Avoid tapping on the table or rustling papers.
 - Avoid typing while unmuted.

Accessibility Features

Poly products include a number of features to accommodate users with disabilities.

Users Who Are Deaf or Hard of Hearing

Your device includes accessibility features for users who are deaf or hard of hearing to use the system.

The following table lists the accessibility features for users who are deaf or hard of hearing.

Table 2-4 Accessibility Features for Users Who Are Deaf or Hard of Hearing

Accessibility Feature	Description
Status indicator lights	The device shows status info using LED pattern behaviors and colors.

Users with Limited Mobility

Your device includes accessibility features to enable users with limited mobility to use various device features.

The following table lists the accessibility features for users with limited mobility.

Table 2-5 Accessibility Features for Users with Limited Mobility

Accessibility Feature	Description
Built-in Speaker and Microphone	Your Poly Studio P5 has an integrated microphone that enables you to speak without using a headset.

Using Your Poly Studio P Series Device

Connect your Poly Studio P Series device to your computer with the provided USB cable.

Once you plug in the device, you can start using it.

Default Poly Studio P Series Device Features

Several features are enabled by default on your device. You can change or disable some of these features using Poly Lens Desktop App.

Poly Studio P5 Features

The following features are enabled by default:

- Camera autofocus

Download and Install the Poly Lens Desktop App

Download the Poly Lens Desktop App to access configuration settings and features.

See the [Poly Lens Desktop App User Guide](#) for information on using your device with Poly Lens Desktop.

 **NOTE:** The Poly Lens application is not supported on Chromebooks at this time.

1. Go to the [Poly Lens App](#) product page.
2. Select the applicable download for your operating system.
3. Follow the onscreen installation instructions.

Set Poly P Series Device as the Default Audio and Video Device

When you use the Poly Studio P5 webcam with a supported application for video calls, you may need to set the device as the default audio and video device of your application.

The following is a general procedure that you can refer to. Your application may use different terms or categories.

1. Go to your conferencing application's **Settings**.

2. Find **Audio Device** and **Video Device**.
3. Choose your Poly Studio P Series device as the device for each category.

Restart Your Device

If you encounter issues with your device, you can try restarting it.

- To restart your Poly Studio P5, unplug the USB cable from your computer and plug the cable back into your computer.

The device powers off and restarts after you plug it back in. You may need to reselect the device as the default audio and video device for your conferencing software.

Updating Firmware

Your device can automatically download firmware updates through Windows Update, Poly Lens Desktop, or directly from Poly Lens on a conferencing PC provisioned with Poly Lens Room.

Poly Lens Desktop notifies you when a device firmware update is available.

 **NOTE:** MacOS doesn't support automatic updates. Use the Poly Lens Desktop app to update the firmware.

For more information on updating your device, refer to the [Poly Lens Desktop App User Guide](#).

Getting help

Poly is now a part of HP. The joining of Poly and HP will pave the way for us to create the hybrid work experiences of the future.

During the merge of our two organizations, information about Poly products will transition from the [Poly Support](#) site to the [HP® Support](#) site.

The [Poly Documentation Library](#) will continue to host the installation, configuration, and administration guides for Poly products in HTML and PDF format. In addition, the Poly Documentation Library will provide Poly customers with up-to-date status information about the transition of Poly content from the [Poly Support](#) site to the [HP® Support](#) site.

HP Inc. addresses

HP US

HP Inc.
1501 Page Mill Road
Palo Alto 94304, U.S.A.
650-857-1501

HP Germany

HP Deutschland GmbH
HP HQ-TRE
71025 Boeblingen, Germany

HP UK

HP Inc UK Ltd
Regulatory Enquiries, Earley West
300 Thames Valley Park Drive
Reading, RG6 1PT
United Kingdom

Document information

Document part number: P43848-001

Last update: February 2025

Email us at documentation.feedback@hp.com with queries or suggestions related to this document.