



# CORDLESS SNOW SHOVEL

24V\* IONMAX | 4.0 Ah | 12-INCH

OPERATOR'S MANUAL

Model 24V-SS12-HT

Form No. SJ-24V-SS12-HT-880E-M

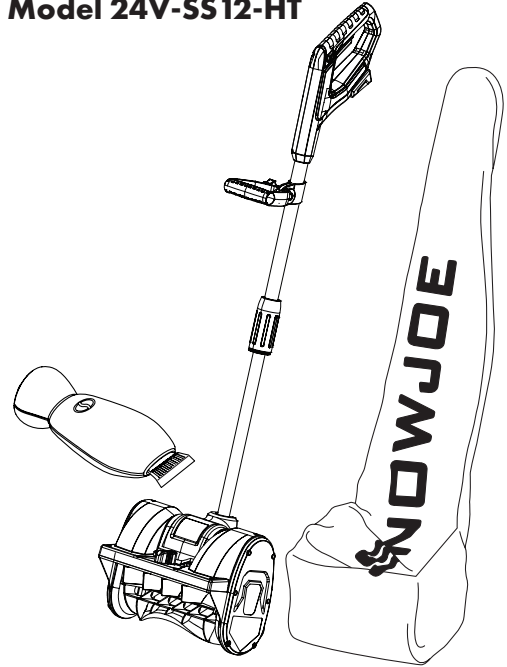

THANK YOU FOR YOUR PURCHASE!

HAS YOUR SNOW JOE EXPERIENCE LEFT YOU SMILING? 😊

TELL YOUR FRIENDS AND TAG US!

We love to hear your feedback! Share your experience by writing comments and reviews on [shopjoe.com](http://shopjoe.com), or connect with us on social media!



@SNOWJOECO

#GOWITHJOE

OR HAS SOMETHING LEFT YOU LESS THAN SATISFIED? 😞

WE'RE SORRY ABOUT THAT!

Our friendly customer service team is ready to help you with any issues you may have, Monday – Sunday from 9AM to 5PM EST

CALL US, EMAIL US, CHAT WITH US

HELP@SHOPJOE.COM For fastest response

SHOPJOE.COM

SCAN REGISTER ONLINE TODAY



Place UPC sticker here

- ✓ ACTIVATE YOUR **2 YEAR WARRANTY**
- ✓ RECEIVE **90 DAYS BONUS COVERAGE**
- ✓ VISIT **SHOPJOE.COM/REGISTER**

Failure to register your product purchase will not diminish your warranty rights. For more information visit [shopjoe.com](http://shopjoe.com)



UPGRADE YOUR COVERAGE AT SHOPJOE.COM/REGISTER FOR UP TO 3, 4, OR 5 YEARS OF TOTAL TOOL COVERAGE

When we say we stand behind our product, we mean it! Now you can blow, mow, cut, saw or tend to any other yard task with confidence, knowing that if there is a problem with your tool within the warranty period, we will gladly solve it.

Original instructions. © 2024 All Season Power LLC. Snow Joe®, Sun Joe®, Aqua Joe®, Auto Joe®, and Power Joe® are registered trademarks used under license from Weather Brands LLC.

\*DISCLAIMER: Initial no-load voltage, when fully charged, peaks at 24V; nominal voltage under typical load is 21.6V.

SAVE THESE INSTRUCTIONS





SNOWJOE®

# CORDLESS SNOW SHOVEL

24V\* IONMAX | 4.0 Ah | 12-INCH

OPERATOR'S MANUAL

Model 24V-SS12-HT

Form No. SJ-24V-SS12-HT-880E-M

EN

## IMPORTANT!

### Safety Instructions

### All Operators Must Read These Instructions Before Use

Read all instructions before using this cordless snow shovel. Basic safety precautions should always be followed to reduce the risk of fire, electric shock and personal injury.

### General Safety

You and any other operator of this snow shovel must read, understand and follow these instructions in their entirety, and should reread them at the start of each snow season. Failure to follow these instructions may result in ELECTRIC SHOCK, FIRE and/or serious PERSONAL INJURY.

**Notice the personal safety alert symbol  used in this manual to draw your attention to a WARNING given along with the particular operating instruction. This means that the operation requires special ATTENTION, CAUTION and AWARENESS.**

** WARNING!** When using the power tool, basic safety precautions should always be followed to reduce the risk of fire, electric shock, and personal injury. These include:

- **Keep work area clean and well lit** – Cluttered, dark areas invite accidents.
- **Use the right product** – Do not use this machine for any job except that for which it is intended.
- **Replacement parts** – When servicing this unit, use only identical replacement parts. Replace or repair damaged cord immediately on the charger.  
  
Do not use on gravel surfaces unless the snow shovel is adjusted for such surfaces in accordance with the operator's manual.
- **Keep children, bystanders and pets away** – All spectators, including pets, should be kept a safe distance away from the work area.

- **Dress properly** – Do not wear loose articles of clothing or jewelry. They can become caught in moving parts. Wear rubber boots.  
  
The cordless snow shovel should not be operated in the hand-held position except when the instructions provided in this manual deem such use permissible.
- **Avoid accidental starting** – Make sure the safety switch and the on/off switch are in the off position before inserting the battery in the unit. Do not carry the cordless snow shovel with the safety switch and the on/off switch engaged.
- **Moving parts** – Keep hands and feet away from moving parts. Keep guards in place and in proper working order.
- ** CAUTION!** Exercise caution to avoid slipping or falling. Wear protective footwear that will protect your feet and improve your footing on slippery surfaces.
- **Use safety glasses** – Also use safety footwear, snug-fitting clothing and gloves.
- **Stay alert** – Watch what you are doing. Use common sense. Do not operate the cordless snow shovel when you are tired or under the influence of alcohol or drugs.
- **Do not force the tool** – It will perform better with less likelihood of personal or mechanical injury if it is used at the rate for which it was designed.
- **Do not overreach** – Keep proper footing and balance at all times.
- If the cordless snow shovel strikes a foreign object, follow these steps:
  - Stop the cordless snow shovel. Remove the battery.
  - Inspect for damage.
  - Repair any damage before restarting and operating the snow shovel.
- **Disconnect the tool** – Turn off the power switch and remove the battery when it is not in use, before servicing it, when changing accessories and when performing any other maintenance task.
- **Store idle tool indoors** – When not in use, the cordless snow shovel should be stored indoors in a dry, locked place out of the reach of children.
- **Maintain the cordless snow shovel with care** – Follow the applicable maintenance instructions for replacing parts and changing accessories. Lubrication is not required.

# Battery & Charger

## Safety Instructions

We pay a great deal of attention to the design of every battery pack to ensure that we supply you with batteries that are safe, durable and have a high energy density. The battery cells have a wide range of safety devices. Each individual cell is initially formatted and its electrical characteristic curves are recorded. This data is then used exclusively to assemble the best possible battery packs.

Despite all the safety precautions, caution must always be exercised when handling batteries. The following points must be obeyed at all times to ensure safe use. Safe use can only be guaranteed if undamaged cells are used. Incorrect handling of the battery packs can cause cell damage.

**IMPORTANT!** Analyses confirm that incorrect use and poor care of high-performance batteries are the main factors responsible for product damage and/or personal injury.

 **WARNING!** To reduce the risk of injury, use only official 24V\* IONMAX™ designated chargers and battery packs. The use of other batteries or chargers poses a risk of fire, personal injury and damage.

 **WARNING!** Do not use a battery pack or product that has been damaged or modified. Damaged or modified batteries may exhibit unpredictable behavior resulting in fire, explosion or risk of injury.

Do not modify or attempt to repair the product or the battery pack except as indicated in the instructions for use and care. Do not wire a battery pack to a power supply or car cigarette lighter, as such misuse will permanently disable or damage the battery pack.

Have your battery pack serviced by a qualified repair person using only identical replacement parts. This will ensure that the safety of the battery pack is maintained.

 **WARNING!** To reduce the risk of electric shock, always unplug the charger before performing any cleaning or maintenance. Do not allow water to flow into the charger. Use a Ground Fault Circuit Interrupter (GFCI) to reduce shock hazards.

- **Remove battery** – Remove the battery pack from the tool when not in use, before servicing, or before performing any other maintenance task. Never leave the tool unattended while switched on. In the event of an accident or breakdown, switch off the tool immediately.
- **Avoid dangerous environments** – Do not charge the battery packs in rain, snow or in damp or wet locations. Do not use the battery pack or charger in the presence of explosive atmospheres (gaseous fumes, dust or flammable materials) because sparks may be generated when inserting or removing the battery packs, which could lead to a fire.

**NOTE:** The safe temperature range for the batteries are 41°F (5°C) to 105°F (40.5°C). Do not charge the batteries outside in freezing weather; charge them at room temperature.

- **Charge in a well-ventilated area** – Do not block the charger vents. Keep them clear to allow for proper ventilation. Do not allow smoking or open flames near a charging battery pack. Vented gases may explode.
- **Maintain charger cord** – When unplugging the charger, pull the plug, not the cord from the receptacle to reduce the risk of damage to the power cord. Never carry the charger by its cord. Keep the cord away from heat, oil and sharp edges. Make sure the cord will not be stepped on, tripped over or subjected to damage or stress when the charger is in use. Do not use a charger with a damaged cord or plug. Replace a damaged charger immediately.
- **Do not use an extension cord unless it is absolutely necessary** – Using the wrong, damaged or improperly wired extension cord poses a risk of fire and electric shock. If an extension cord must be used, plug the charger into a properly wired 16 gauge or larger extension cord with the female plug matching the male plug on the charger. Make sure that the extension cord is in good electrical condition.
- **Do not expose the machine or battery packs to fire** – Exposure to fire or temperatures above 265°F (130°C) may cause the battery packs to explode, causing personal injury or damage. Toxic fumes and materials are created when battery packs are ignited.
- **Do not crush, drop or damage battery packs** – Do not use the battery packs or charger if they have sustained a sharp blow, been dropped from a height of more than 3 feet (1 meter), run over or have been damaged in any way. Even if the housing of a battery pack appears to be undamaged, the battery cells inside the battery may have suffered serious damage. In such instances, please read the waste disposal information for proper battery disposal.
- **Do not disassemble** – Incorrect reassembly may pose a serious risk of electric shock, fire or exposure to toxic battery chemicals. If the battery or charger is damaged, contact an authorized Snow Joe® + Sun Joe® dealer or call the All Season Power customer service center at 1-866-225-9723 for assistance.
- **Battery chemicals cause serious burns** – Never let a damaged battery pack contact the skin, eyes or mouth. If damaged, battery chemicals will react violently with air. Use rubber or neoprene gloves to safely dispose of the battery. If skin is exposed to battery chemicals, wash the affected area with soap and water. If eyes are exposed to battery chemicals, immediately flush with water for 20 minutes and seek medical attention. Remove and dispose of contaminated clothing.
- **Risk of short circuit** – A battery pack will short circuit if a metal object makes a connection between the positive and negative contacts on the battery pack. Do not place a battery pack near anything that may cause a short circuit, such as paperclips, coins, keys, screws, nails and other metallic objects. A short-circuited battery pack poses a risk of fire and severe personal injury.

- **Store your battery packs and charger in a cool, dry place** – Ideally, store the battery packs at 59°F (15°C) and charged to at least 40%. Do not store the battery packs or charger where temperatures may exceed 105°F (40.5°C), such as in direct sunlight or inside a vehicle, or where temperatures may drop below 41°F (5°C).

**NOTE:** Prevent the battery packs from freezing. Battery packs that were stored below 32°F (0°C) for more than 60 minutes must be discarded.















- **Charge before use** – The battery pack supplied with your machine is only partially charged. The battery pack must be fully charged before using the shovel for the first time.
- **Battery Aging** – Lithium-ion batteries are subject to a natural aging process. A battery pack must be replaced at the latest when its capacity falls to just 80% of its capacity when new. Weakened cells in an aged battery pack are no longer capable of meeting the high power requirements needed for the proper operation of your machine, and therefore pose a safety risk.
- **Do not exhaustively discharge battery packs** – A complete discharge will damage the battery cells. The most common cause of exhaustive discharge is lengthy storage. Stop working as soon as the performance of a battery falls noticeably or the electronic protection system triggers. For optimum battery performance, charge the battery packs frequently. Place the battery packs in storage only after they have been fully charged.
- **Do not overload battery packs** – Protect the shovel and battery from overloading. Overloads will quickly result in overheating and cell damage inside the battery housing even if it is not apparent externally. For safety reasons, the integrated protective cutoff will activate to switch off the equipment. After regular use, allow the battery packs to cool to room temperature before recharging them.

**IMPORTANT!** Do not attempt to turn on the machine if the protective cutoff has been activated. This may damage the battery packs.

- **Outlet voltage** – Please check the data marked on the rating label of the battery charger. Be sure that the voltage of the power supply matches that marked on the rating label. Never connect it to a different mains voltage.
- **Charger use** – Do not use the supplied battery charger to charge other types of battery packs or tools.
- **Do not overcharge battery packs** – Do not exceed the maximum charging times. Frequently overcharging the battery packs will result in cell damage. Do not leave battery connected to the charger for days on end.
- **Battery pack abnormalities** – Do not use batteries that have suffered swelling or deformation or those that exhibit other atypical symptoms (gassing, hissing, cracking, etc.).
- **Electrostatic discharge** – When handling batteries, be wary of electrostatic charge. Electrostatic discharges can damage the electronic protection system and the battery cells. To avoid electrostatic discharges, never touch the battery terminals.

# Safety Symbols

The following table depicts and describes safety symbols that may appear on this product. Read, understand, and follow all instructions on the product before attempting to assemble and operate.

Symbols	Descriptions	Symbols	Descriptions
	<b>READ THE OPERATOR'S MANUAL(S)</b> – Read, understand and follow all instructions in the user manual(s) before attempting to assemble and operate.		<b>WARNING!</b> Do not expose the unit to rain or wet conditions. Keep dry.
	<b>SAFETY ALERT</b> – Indicates a precaution, a warning or a danger.		<b>CAUTION!</b> Beware of stones and other foreign objects that could be thrown from the appliance.
	Wear eye protection.		Wear gloves during use to protect hands.
	Keep bystanders and children a safe distance (at least 11 yd/10 m) away from the work area.		Wear safety footwear at all times.
	<b>DANGER!</b> Cutting/dismemberment hazard - Keep hands away from the rotating auger.		<b>DANGER!</b> Cutting/dismemberment hazard - Keep feet away from the rotating auger.
	Keep hands, feet and clothing away from the rotating auger to avoid injury.		Do not use hands to unclog the auger.
	The rotating part will continuously run for several seconds after you turn off the machine.		Only use battery charger indoors.

# Know Your 24V Max\* Cordless Snow Shovel

Read the owner's manual and safety instructions carefully before operating the snow shovel. Compare the illustration below to the product in order to become familiar with the location of the various controls and adjustments. Save this manual for future reference.

1. Safety switch
2. On/off trigger switch
3. Battery compartment
4. Motor housing
5. Scraper bar
6. Lower pole
7. Angle control lever
8. Shovel blade
9. 24V\* IONMAX™ lithium-ion battery quick charger (24VCHRG-QC)
10. 24V\* IONMAX™ lithium-ion battery (24VBAT) featuring exclusive EcoSharp® technology
11. Battery indicator
12. Locking collar
13. Upper pole
14. Auxiliary handle
15. Protective cover
16. Ice scraper + polar fleece mitt

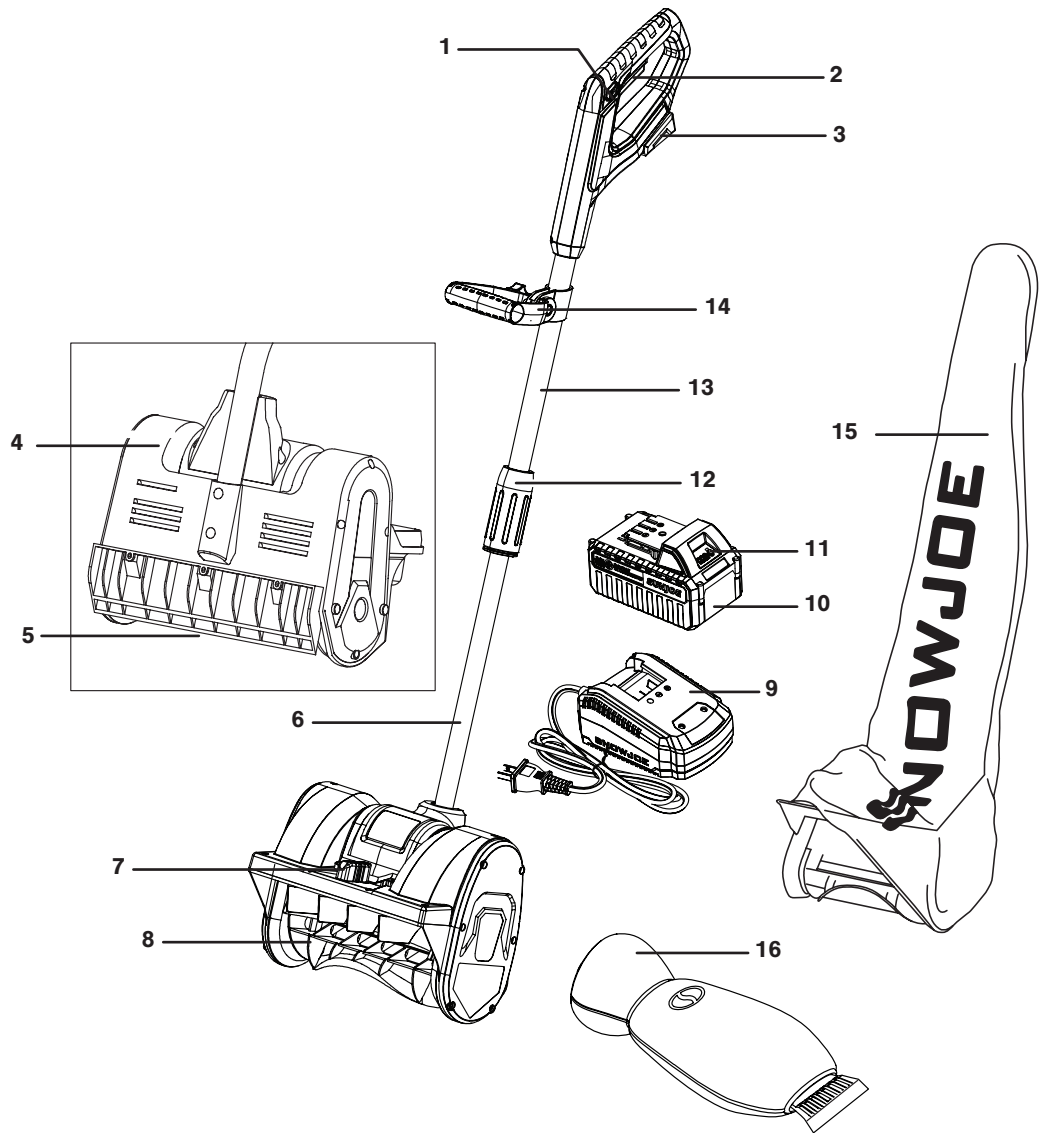

## Technical Data

Motor.....	500 W	Rotor.....	2-blade paddle auger
Battery Voltage Max* .....	24V DC	No Load Speed.....	2200 RPM
Battery Capacity.....	4.0 Ah	Clearing Width.....	12 in. (30.5 cm)
Charger Input .....	120V AC, 60 Hz, 75 W	Depth of Snow Cut Max.....	6 in. (15 cm)
Charger Output .....	26V DC, 2.2A	Throw Distance Max .....	20 ft (6 m)
Charge Time Max .....	1 hr 50 min	Net Weight .....	12.6 lbs (5.7 kg)

**\*DISCLAIMER:** Initial no-load voltage, when fully charged, peaks at 24V; nominal voltage under typical load is 21.6V.

# Unpacking

## Carton Contents

- Cordless snow shovel
- Handle assembly
- Knob
- 24V\* IONMAX™ lithium-ion battery
- 24V\* IONMAX™ lithium-ion charger
- Protective cover
- Ice scraper + polar fleece mitt
- Manual with registration card

1. Carefully remove the cordless snow shovel and check to see that all of the above items are supplied.
2. Inspect the product carefully to make sure no breakage or damage occurred during shipping. If you find damaged or missing parts, DO NOT return the unit to the store. Instead, please call the All Season Power customer service center at 1-866-225-9723.

**NOTE:** Do not discard the shipping carton and packaging materials until you are ready to use your new cordless snow shovel. The packaging is made of recyclable materials. Properly dispose of these materials in accordance with local regulations.





**IMPORTANT!** The equipment and packaging materials are not toys. Do not let children play with plastic bags, foils or small parts. These items can be swallowed and pose a suffocation risk!

## Battery Pack Operation

The equipment is powered by a lithium-ion battery. The battery pack is completely sealed and maintenance-free.

### Battery Charge Level Indicator

The battery pack is equipped with a push button for checking the charge level. Simply press the push button to read off the battery charge level from the LEDs of the battery indicator:

Lights	Light Indicators
	
	Charge level button
	The battery is at 30% capacity
	The battery is at 60% capacity
	The battery is fully charged

**NOTE:** If the battery indicator button does not appear to be working, charge the battery.

**NOTE:** Immediately after using the battery pack, the battery indicator may display a lower charge than it will if checked a few minutes later. The battery cells “recover” some of their charge after resting.

## Charger Operation

**⚠️WARNING!** Only charge Sun Joe® 24V lithium-ion battery packs with compatible Sun Joe® 24V lithium-ion chargers. Other types of chargers may cause personal injury and damage.

To reduce the risk of electric shock, do not allow water to enter into the charger.

### Charging the Battery

1. Push the push lock buttons on either side of the battery pack to pull it out from the battery compartment (Fig. 1).

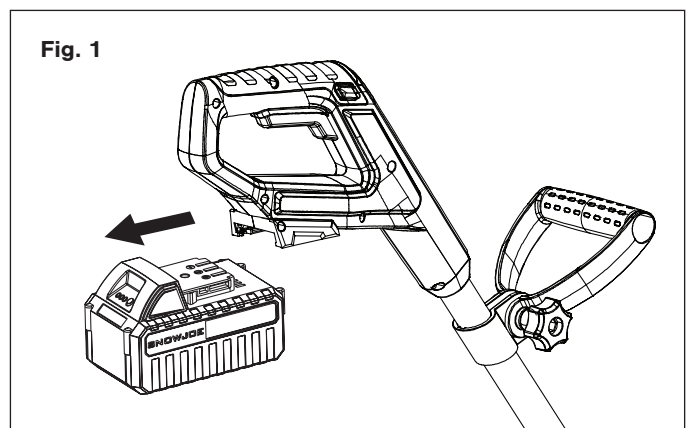

2. Check that the mains voltage is the same as that marked on the rating plate of the battery charger. Then, insert the charger's plug into the electrical wall outlet. When you plug in the charger, the top right green light will illuminate and stay green (Fig. 2).

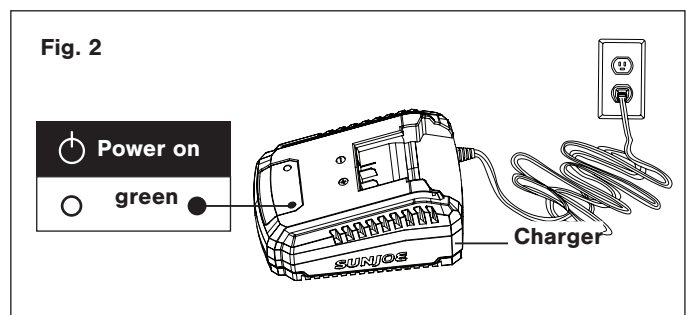

3. Place the battery pack into the charger by sliding the pack to lock it into position. When you insert the battery into the charger, the top right green light will go off, and the top left red light will illuminate to indicate that the battery is charging (Fig. 3).

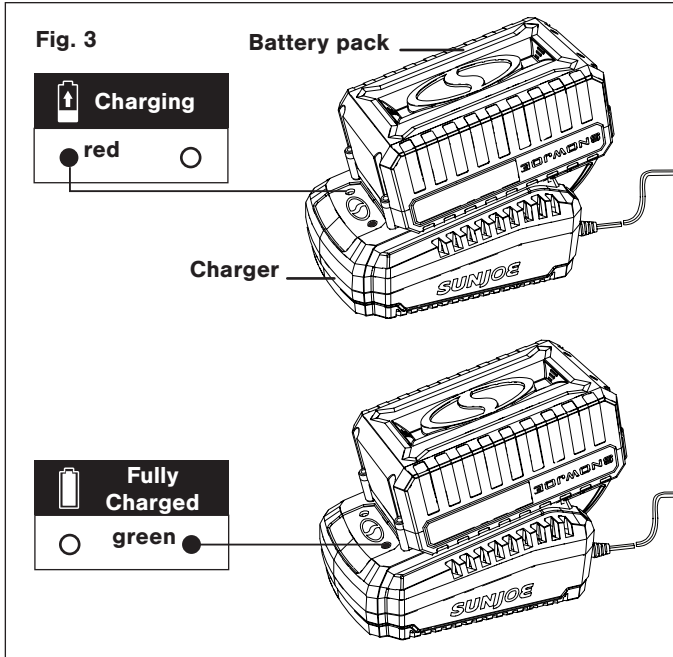

4. When the charger light turns green, the battery is fully charged (Fig. 3).

**NOTE:** A fully discharged pack with an internal temperature in the normal range will fully charge in 1 hr 50 mins (between 32°F/0°C and 113°F/45°C).

- If the light indicators do not come on at all, check that the battery pack is fully seated into the bay by removing the battery pack and reinserting. If the problem persists, contact an authorized Snow Joe® + Sun Joe® dealer or call the All Season Power customer service center at 1-866-225-9723 for assistance.
- When charging is complete, remove the battery from the charger by pressing the push lock buttons and sliding the battery backward to unlock it from the charger (Fig. 4).

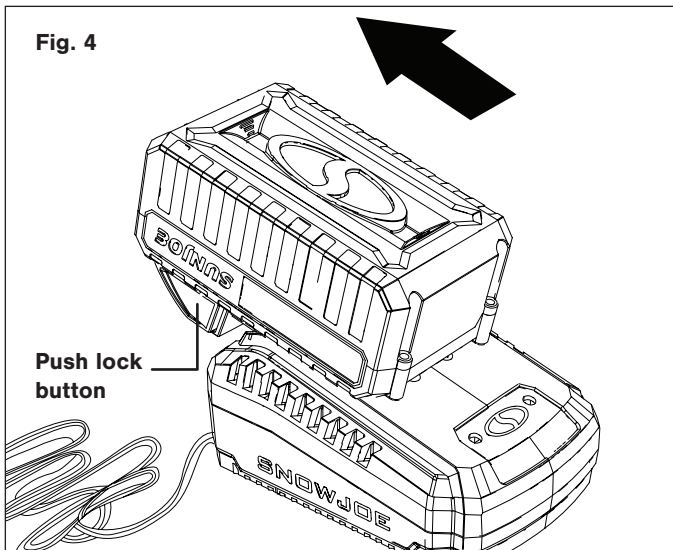

7. Timely recharging of the battery will help prolong the battery's life. You must recharge the battery pack when you notice a drop in the equipment's power.

**IMPORTANT!** Never allow the battery pack to become fully discharged as this will cause irreversible damage to the battery.

### Charging a Hot or Cold Battery Pack

The green indicator light on the charger base indicates that the battery pack temperature is outside the charging range. Once the pack is within the acceptable range, normal charging will take place and the red light will be continuous. Hot or cold battery packs may take longer to charge.

Lithium-Ion Charging Status			
Battery Pack Temperature	Charger Base Indicator Light	Battery Pack Indicator Light	Charging Status
Too hot	Green	Flashing together	Not charging
Normal range	Red	Flashing one by one	Normal charging
Too cold	Green	Flashing together	Not charging

### Assembly

Slide the upper pole onto the lower pole. Align and secure together by twisting the locking collar (Fig. 5).

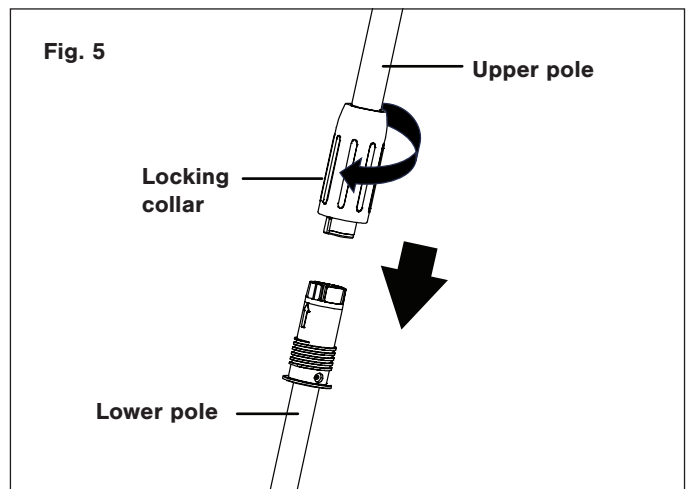



## Operation

**⚠ WARNING!** Keep the area to be cleared free of stones, toys or other foreign objects that the rotor blades might pick up and throw. Such items could be covered by snow and are easy to overlook, so be sure to conduct a thorough inspection of the area before beginning work.

### Starting the Machine

1. Slide the battery down in the battery compartment until it clicks to lock it into position (Fig. 6).

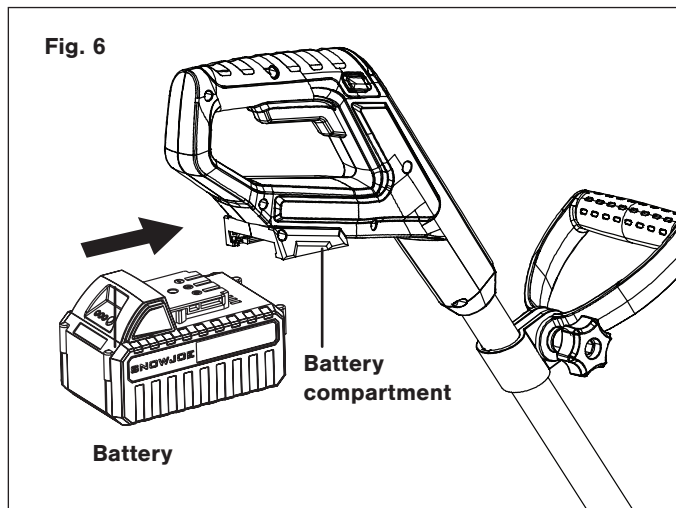

2. To start the cordless snow shovel, push and hold the safety lock switch on the side of the handle grip with your thumb and then squeeze the trigger switch with your fingers. Once the machine powers on, you can release the safety lock switch and proceed with operation (Fig. 7).

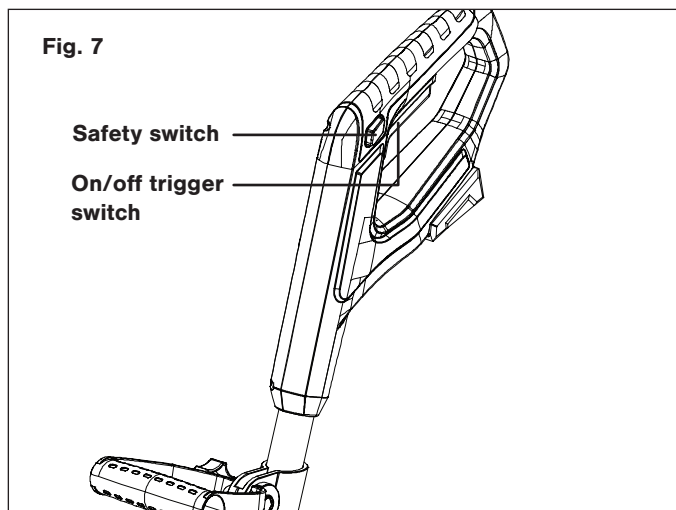

3. To stop the cordless snow shovel, release the trigger switch.

### Auxiliary Handle Adjustment

To adjust the angle of the auxiliary handle, follow the instructions below:

1. Stop the machine and remove the battery. Wait until the blade comes to a complete stop.
2. Loosen the auxiliary handle by turning the handle knob counterclockwise. Rotate the auxiliary handle to a comfortable position (Fig. 8).

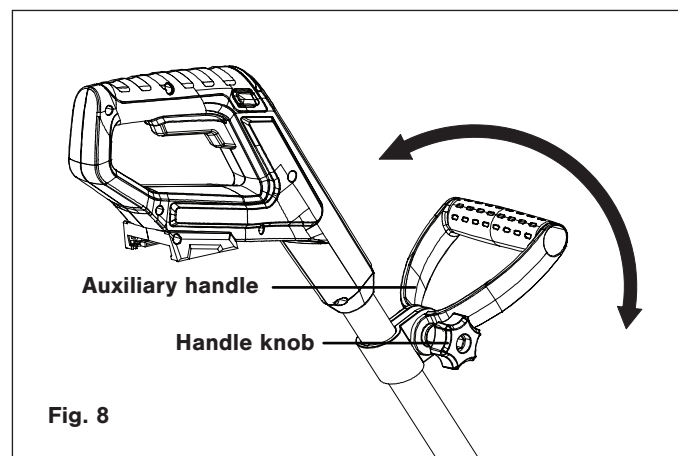

3. Fix the handle by tightening the handle knob. Insert the battery and resume working.

### Operating Tips

- Start the cordless snow shovel. Push the shovel forward at a comfortable rate, yet slow enough to clear the path completely. The clearing width of the snow shovel and the depth of snowfall should dictate your forward speed.
- Direct the snow discharge to the right or to the left using the angle control lever. Turn it right to go left and turn it left to go right (Fig. 9).

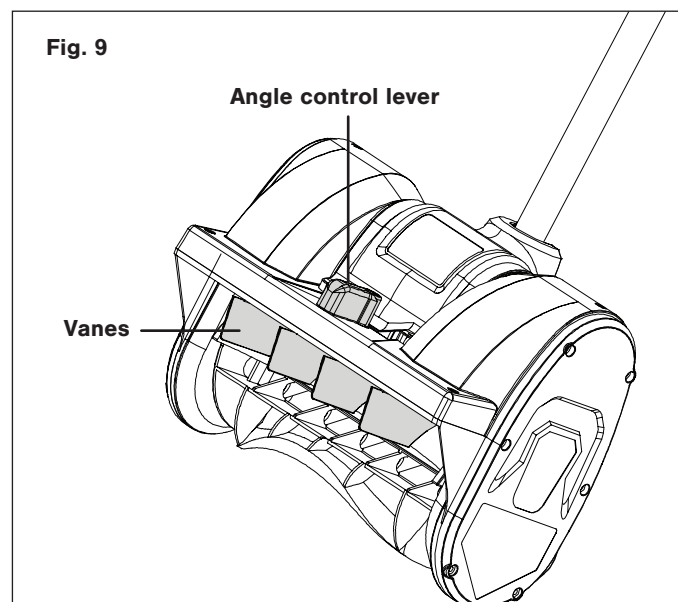

- To remove snow most efficiently, throw the snow downwind and slightly overlap each swath.
- If you need to clear snow from a crushed rock or gravel surface, push down on the handle to keep the scraper blade clear of any loose material that the rotor blades could throw.
- This cordless snow shovel cuts a path 12 in. (30 cm) wide and up to 6 in. (15 cm) deep in one pass.
- When clearing deeper drifts, hold the cordless snow shovel by the upper and auxiliary handles and use a swinging or sweeping motion. Remove up to 6 in. (15 cm) of snow with each pass and repeat as many times as needed.
- Remove the battery after using the cordless snow shovel. Hang the shovel so it will not be misplaced or damaged.

## Maintenance

To order genuine replacement parts or accessories for the Snow Joe® 24V-SS12-HT Cordless Snow Shovel, please visit [shopjoe.com](http://shopjoe.com) or contact the All Season Power customer service center at 1-866-225-9723.

### Proper Care for Battery + Charger

**⚠️ WARNING!** To reduce the risk of injury, always unplug the charger and remove the battery pack from the charger before performing any maintenance task. Never disassemble the battery pack or charger. Contact your Snow Joe® + Sun Joe® dealer or the All Season Power customer service center for ALL repairs.

- To reduce the risk of injury and damage, never immerse your battery pack or charger in liquid or allow any liquid to flow inside these components.
- Clean out dust and debris from charger vents and electrical contacts by blowing with compressed air.
- Only use a dry cloth to clean the battery pack and charger, keeping away from all electrical contacts. Certain cleaning agents and solvents are harmful to plastics and other insulated parts. Some of these include gasoline, turpentine, lacquer thinner, paint thinner, chlorinated cleaning solvents, ammonia and household detergents containing ammonia. Never use flammable or combustible solvents around battery packs, battery chargers or tools.
- The IONMAX™ 24VCHRG-QC lithium-ion battery charger has no serviceable parts.

### Lubricating the Cordless Snow Shovel

This cordless snow shovel does not need lubrication. All bearings are lubricated at the factory for the life of the product.

## Storage

1. Examine the cordless snow shovel thoroughly for worn, loose or damaged parts. Should you need to repair or replace a part, contact an authorized Snow Joe® + Sun Joe® dealer or call the All Season Power customer service center at 1-866-225-9723 for assistance.
2. Remove the battery from the cordless snow shovel before storing.
3. Store the cordless snow shovel indoors in a locked, dry place out of the reach of children to prevent unauthorized use or damage.

### Battery + Charger Off-Season Storage

- Do not expose your battery pack or charger to water, rain or allow them to get wet. This could permanently damage the charger and the battery pack. Do not use oil or solvents to clean or lubricate your battery pack, as the plastic casing can become brittle and crack, causing a serious risk of injury.
- Store the battery pack and charger at room temperature away from moisture. Do not store in damp locations where corrosion of terminals may occur. As with other battery pack types, permanent capacity loss can result if the pack is stored for long periods of time at high temperatures (over 120°F/49°C).
- IONMAX™ 24VBAT-XR lithium-ion battery packs maintain their charge during storage longer than other battery pack types. As a general practice, it is best to unplug the battery charger and remove the battery pack when they are not in use. Recharge the battery pack every 6 months to 50% capacity (2 lights on) during off-season storage to maintain optimal battery performance.

## Battery Caution + Disposal

Always dispose of your battery pack according to federal, state, and local regulations. Contact a recycling agency in your area for recycling locations.

**⚠️ CAUTION!** Even discharged battery packs contain some energy. Before disposing, use electrical tape to cover the terminals to prevent the battery pack from shorting, which could cause a fire or explosion.

**⚠️ WARNING!** To reduce the risk of injury or explosion, never burn or incinerate a battery pack even if it is damaged, dead or completely discharged. When burned, toxic fumes and materials are emitted into the surrounding atmosphere.

- Batteries vary according to device. Consult your manual for specific information.
- Install only new batteries of the same type in your product (where applicable).
- Failure to insert batteries in the correct polarity, as indicated in the battery compartment or manual, may shorten the life of the batteries or cause batteries to leak.

- Do not mix old and new batteries.
- Do not mix Alkaline, Standard (Carbon-Zinc) or Rechargeable (Nickel Cadmium, Nickel Metal Hydride, or Lithium-Ion) batteries.
- Do not dispose of batteries in fire.
- Batteries should be recycled or disposed of as per state and local guidelines.

## Service and Support

If your Snow Joe® 24V-SS12-HT Cordless Snow Shovel requires service or maintenance, please call the All Season Power customer service center at 1-866-225-9723.

## Model and Serial Numbers

When contacting the company, reordering parts or arranging service from an authorized dealer, you will need to provide the model and serial numbers, which can be found on the decal located on the housing of the unit. Copy these numbers into the space provided below.

Record the following numbers from the housing or handle of your new product:	
Model #:	Serial #:
2 4 V - S S 1 2 - H T	

## Federal Communications Commission (FCC) Supplier's Declaration of Conformity

### Product information:

**Product Name:** ..... CLASS 2 BATTERY CHARGER  
**Model No.:** ..... 24VCHRG-QC  
**Trade Mark:** .....N/A  
**Applicable standards:** .....CFR 47 PART 15 (2019) / ANSI C63.4 (2014)

This device complies with part 15 of the FCC Rules. Operation is subject to the following two conditions:

- (1) This device may not cause harmful interference, and
- (2) this device must accept any interference received, including interference that may cause undesired operation.

The test result has been evaluated by Interek Testing Services Shanghai Laboratory and showed in the test report.

**CAUTION!** Changes or modifications to this unit not expressly approved by the party responsible for compliance could void the user's authority to operate the equipment.

**NOTE:** This equipment has been tested and found to comply with the limits for a Class B digital device, pursuant to part 15 of the FCC Rules.

These limits are designed to provide reasonable protection against harmful interference in a residential installation.

This equipment generates, uses and can radiate radio frequency energy and, if not installed and used in accordance with the instructions, may cause harmful interference to radio communications.



However, there is no guarantee that interference will not occur in a particular installation.

If this equipment does cause harmful interference to radio or television reception, which can be determined by turning the equipment off and on, the user is encouraged to try to correct the interference by one or more of the following measures:

- Reorient or relocate the receiving antenna.
- Increase the separation between the equipment and receiver.
- Connect the equipment to an outlet on a circuit different than the one the receiver is connected to.
- Consult the dealer or an experienced radio/TV technician for help.

## Optional Accessories

**⚠ WARNING!** Only use authorized Snow Joe® + Sun Joe® replacement parts and accessories. NEVER use replacement parts or accessories that are not intended for use with this shovel. Contact All Season Power if you are unsure whether it is safe to use a particular replacement part or accessory with your shovel. The use of any other attachment or accessory can be dangerous and could cause injury or mechanical damage.

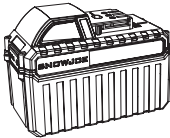
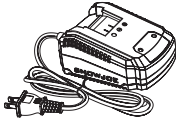
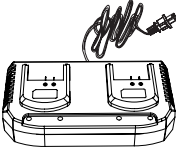
Accessories	Item	Model
<p>①</p> 	24V* IONMAX™ 24V 5.0 Ah Lithium-Ion Battery	24VBAT-XR
<p>②</p> 	24V* IONMAX™ 8.0 Ah Lithium-Ion Battery	24VBAT-XR8
<p>③</p> 	24V* IONMAX™ 12.0 Ah Lithium-Ion Battery	24VBAT-XR12
<p>④</p> 	24V* IONMAX™ Lithium-Ion Battery Quick Charger	24VCHRG-QC
<p>⑤</p> 	24V* IONMAX™ Lithium-Ion Dual-Port Battery Charger	24VCHRG-DPC
<p>Visit <a href="http://shopjoe.com">shopjoe.com</a> for more options</p>		

**NOTE:** Accessories are subject to change without any obligation on the part of All Season Power. Accessories can be ordered online at [shopjoe.com](http://shopjoe.com) or via phone by contacting the All Season Power customer service center at 1-866-225-9723.



## ALL SEASON POWER CUSTOMER PROMISE

**ABOVE ALL ELSE**, All Season Power LLC (“All Season Power”) is dedicated to you, our customer. We strive to make your experience as pleasant as possible. Unfortunately, there are times when a Snow Joe®, Sun Joe®, Aqua Joe®, or Auto Joe® product (“Product”) does not work or breaks under normal operating conditions. We think it’s important that you know what you can expect from us. That’s why we have a Limited Warranty (“Warranty”) for our Products.

### OUR WARRANTY:

All Season Power warrants new, genuine, powered and non-powered Products to be free from defects in material or workmanship when used for ordinary household use for a period of two years from the date of delivery of the Product to the original, end-user purchaser when purchased from All Season Power or from one of All Season Power’s authorized sellers with proof of purchase. Because All Season Power is unable to control the quality of its Products sold by unauthorized sellers, unless otherwise prohibited by law, this Warranty does not cover Products purchased from unauthorized sellers. If your Product does not work or there’s an issue with a specific part that is covered by the terms of this Warranty, All Season Power will elect to either (1) send you a free replacement part, (2) replace the Product with a new or comparable product at no charge, or (3) repair the Product. How cool is that!

**This Warranty gives you specific legal rights, and you may also have other rights which vary from State to State.**

### PRODUCT REGISTRATION:

All Season Power strongly encourages you to register your Product. You can register online at [shopjoe.com/register](http://shopjoe.com/register), or by printing and mailing in a registration card available online from our website, or by calling our Customer Service Department at **1-866-225-9723**, or by e-mailing us at [help@allseasonpower.com](mailto:help@allseasonpower.com). Failure to register your Product will not diminish your warranty rights. However, registering your Product will allow All Season Power to better serve you with any of your customer service needs.

### WHO CAN SEEK LIMITED WARRANTY COVERAGE:

This Warranty is extended by All Season Power to the original purchaser and original owner of the Product.

### WHAT IS NOT COVERED?

This Warranty does not apply if the Product has been used commercially or for non-household or rental applications. This Warranty also does not apply if the Product was purchased from an unauthorized seller. This Warranty also does not cover cosmetic changes that do not affect performance. Wearing parts like belts, augers, chains and tines are not covered under this Warranty, and can be purchased at [shopjoe.com/support](http://shopjoe.com/support) or by calling **1-866-225-9723**.



Keep your warranty intact. Only use **CERTIFIED AUTHENTIC** Snow Joe®, Sun Joe®, Aqua Joe® + Auto Joe® replacement parts + accessories. Use of any other parts + accessories will void the warranty. Genuine parts + accessories can be found and purchased online at [shopjoe.com/support](http://shopjoe.com/support) by entering the model number of your product.



---

---

---

---

---

---

---

---

---

---

---

---

---

---

---

---

---

---

---

---

---

---

---

---



Lined writing area with 20 horizontal lines.



**shopjoe.com**

®